



**THE BEST**

LIGHT AFTER THE SUNSET

**L I G H T**  
**V I S I O N**



# LED-in

STRADALE | STREET

In linea con la filosofia AEC, LED-in vanta un design ricercato e attento ai dettagli, unito alla più avanzata tecnologia e alla ricerca delle migliori prestazioni.

LED-in è stato sviluppato per il solo impiego della tecnologia LED ed è dotato del sistema Comfort Light Optic™ che, attraverso il perfetto controllo dell'emissione luminosa, garantisce eccellenti performance, unite al comfort visivo ed ad un'ottima qualità della luce.

L'ampia gamma di soluzioni drivers (fissi, dimmerabili e telecomandati) permette di ottimizzare ulteriormente le prestazioni dell'apparecchio.

The LED-in luminaire represents the synthesis of AEC philosophy, with a refined design attentive to details that goes hand in hand with the most advanced technology and the research for maximum performance.

LED-in has been developed for the use of LED technology only and features a Comfort Light Optic™ system, which thanks to the perfect control of the light emissions ensures outstanding performance and visual comfort, as well as great light quality. The wide range of driver solutions available (fixed, dimmer and remotely controlled drivers) enables further optimisation of the performance of the units.





LED ITA



LED ENG

**LED-in**

Modello depositato | Registered model

LED-in

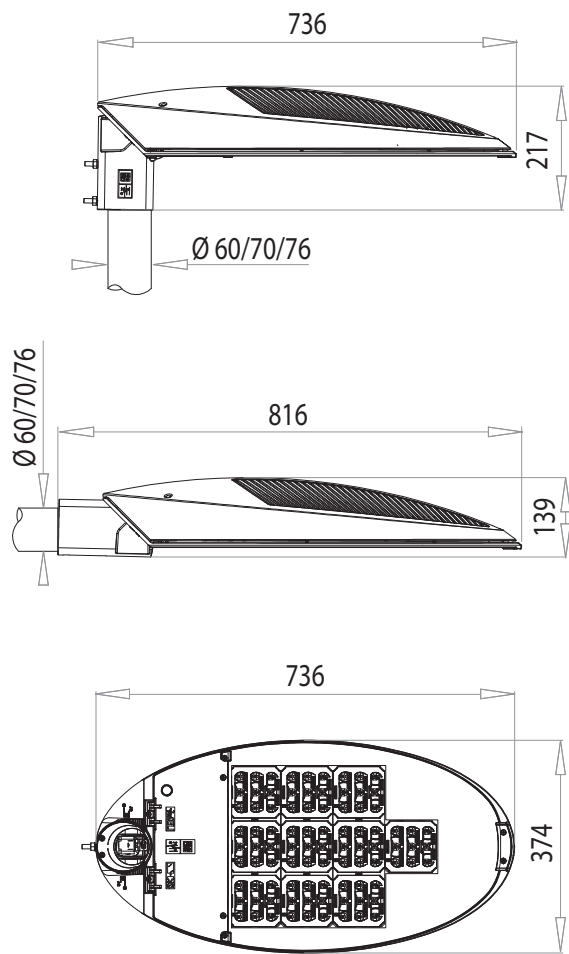

OTTICHE | OPTICS







SISTEMA: APPARECCHIO + PALO | SYSTEM: LUMINAIRE + POLE





PE

PH

PZ

SISTEMA: APPARECCHIO + PALO | SYSTEM: LUMINAIRE + POLE





Faretto LED opzionale su lato marciapiede per illuminazione decorativa disponibile in luce bianca o colore RGB.

Optional decorative LED spotlight on pavement side available in white light or RGB colours.

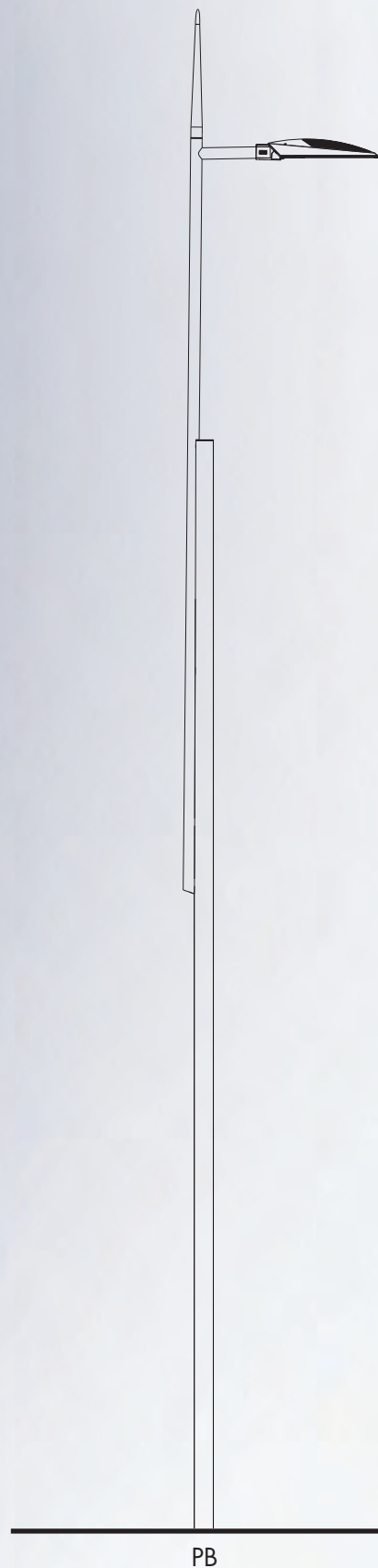



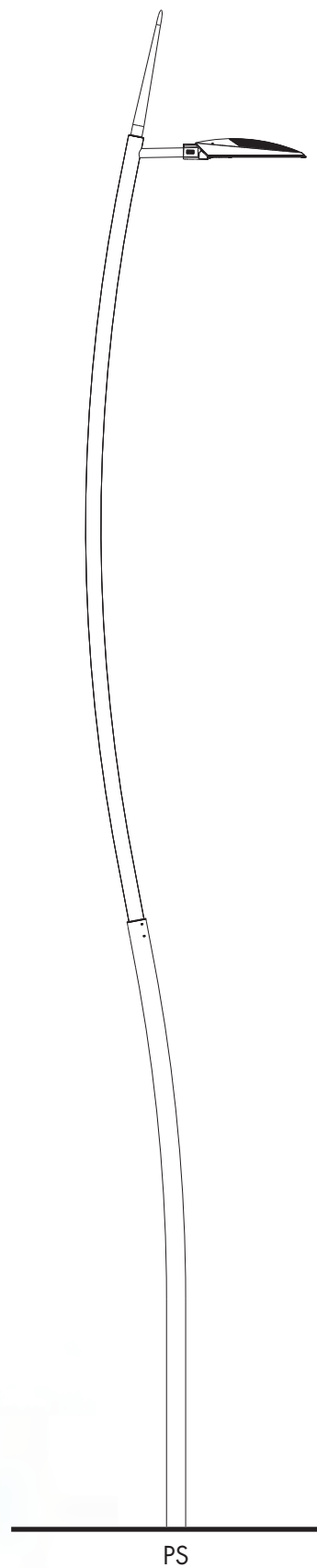



## A12 - ROSIGNANO MARITTIMO (ITALY)

LED-in Apparecchio installato | Installed luminaire





**PIOMBINO**  
**E 80**  
**GROSSETO**  
**ROMA**  
↓

**ROSIGNANO M.**  
↘

ESPOSIZIONE DEL SERVIZIO AUTOMATICO  
INFORMATICO DEL SERVIZIO  
**ROSIGNANO M.**  
**PUNTO**  
↓

**uscita ROSIGNANO M.**

**SS 1**  
**CASTIGLIONE DELLA PESCAIA**  
**ROSIGNANO S. P.**

**SR 206**  
**VADA**

**SR 206**  
**CASTELLINA S. LUCE**

**500**